

6. Locate the Connector/Brass tube assembly in the Gamma Match parts bag and insert the assembly tube first through the connector bracket then thread the connector into the bracket. Be sure to tighten the connector fully. A drop of Loctite® or other threadlock may be used on the connector threads to eliminate the possibility of the connector loosening. See Figure 1 (7/8" boom) or Figure 2 (1-1/4" boom) on the back page for proper orientation.
7. Slide the Gamma Link onto the driven element and assemble the Gamma Match as shown in Figure 1 or 2. Set dimensions "A" and "B" to those shown in Table 1. Setting the match to the dimensions shown for your antenna is a good starting point which will enable you to quickly fine tune later. Complete the assembly by attaching the end cap onto the end of the gamma tube. The antenna is now ready for Final Tuning.

Final Tuning

Before final installation of the antenna, temporarily set it up in a clear area at least 6 feet above the ground. Apply RF power to the antenna and check for low VSWR while performing each of the following steps:

- A. First, loosen the set screw with the allen key provided and make a slight adjustment to the aluminum gamma tube for lowest VSWR.
- B. Next, adjust the gamma link along the driven element for lowest VSWR.
- C. Repeat the above steps until the best match is achieved.
- D. Return to the dimensions shown in Table 1 if there is any trouble achieving a good match.

Important Note: Upon final installation, be sure the gamma match points up towards the sky. Insert boom into the mounting bracket; use hex bolts to tighten securely. Do not exceed 4-6 ft-lbs of torque on the hex bolts.

Weather Proofing

To weatherproof the coax connector and coax cable, slide the sealtube 3 (not included) onto the coax cable. Tighten the coax connector and then position the sealtube over the connector. Heat sealtube with a lighter or other device, taking care not to overheat the tubing. Finish up with a coating of 3M® Scotchkote® for years of performance.

Remember: SURROUNDING OBJECTS, EARTH GROUND AND THE TUNING ENGINEER ALL HAVE A GREAT EFFECT ON VSWR AND RESONANT FREQUENCY! Obstacles in the pattern of the antenna can shift the resonant frequency lower by up to 1 MHz.

Warranty

Laird warrants to the original purchaser that our antennas will remain free from defects in materials and workmanship for a period of one year from the purchase date. If any such defect is discovered within the warranty period, Laird will at its sole option, repair or replace your product free of charge. This warranty applies only if the product is used as designed, and is void if the product is abused, disassembled, tampered with, used unreasonably, or fails as a result of normal wear. Furthermore, this warranty applies only to defects which occur where the proper product is selected as recommended by Laird and is used in the fashion recommended by Laird. This warranty is in lieu of all other warranties, expressed or implied, and is limited to a period of two years from the date of original purchase. Laird is not liable for incidental or consequential damages of any kind. Any warranty extended herein shall be limited to the price paid to Laird for the defective product. Where the period of warranty is governed by state or local law such period shall control.

WARNING!
YOU CAN BE KILLED IF THIS ANTENNA COMES NEAR OR IN CONTACT WITH AN ELECTRIC POWER LINE.
ALWAYS USE CAUTION WHEN INSTALLING THIS ANTENNA. STAY AWAY FROM ALL OVERHEAD WIRES OF ANY KIND.



Smart Technology. Delivered.

Yagi Tuning & Assembly Data

Introduction

Your new Laird Yagi antenna has been designed for accuracy, durability and value. Electrical designs are optimized using the latest in computer aided technology. For fully welded and anodized models, all critical element to boom joints are welded, the entire antenna is anodized, a heavy duty anodized cast mounting kit is included and the antenna is internally matched. This provides for extremely high durability, resistance to corrosion and an accurate radiation pattern.

Warning! Use extreme caution when installing this antenna. Electrocution and/or death can occur if this antenna comes in contact with or comes near electric power lines.

400 to 1000 MHz Pre-Assembled & Welded Yagi Antennas

The internally matched, fully assembled and welded Yagi antenna for frequencies above 400 MHz is factory tuned to the middle of the operating frequency range. The antenna features broad bandwidth and low VSWR across the band. No further adjustment to the antenna is necessary. It is suggested, however that before permanently mounting the antenna it should be checked for low VSWR. This can be done by temporarily positioning the antenna on a mast at least four (4) feet above the ground and away from surrounding objects. Apply RF power to the antenna and check for resonance.

Upon installation of the antenna, after installing the coax to the end of the boom, be sure to relieve the strain on the feed joint. This can be accomplished by looping the coax to the mast, secure the coax to the mast with a nylon tie and then route it down the mast to the final amplifier.

Important Note: Insert boom into the mounting bracket; use hex bolts to tighten securely. Do not exceed 4-6 ft-lbs of torque on the hex bolts.

VHF User-Assembled Yagi Antenna

Follow the instructions listed below to assemble your VHF Yagi Antenna:

Assembly Steps

1. Unpack the antenna and locate the following parts:
Boom (1-1/4" dia. for five element model, 7/8" dia. for three element model)
3/8" Diameter Elements (Y—3 = three elements, Y—5 = five elements)
Gamma Match parts bag
Mounting Bracket parts bag
2. To assemble a factory tuned model, locate the 3/8" diameter elements and proceed to step five.
3. Field tunable models are shipped with the 3/8" diameter elements trimmed to the lowest frequency. In order to tune your antenna to another frequency in its range, locate the elements and proceed to step four.
4. Find the proper element dimension chart for your antenna on the next page and trim each element according to your operating frequency. Use care to trim equal lengths from each end of each element as there is a threaded mounting hole at the center. **This mounting hole must be at the center of the element after trimming!**
5. Insert the elements into their respective locations through the boom starting with R₁ (the reflector element) in the hole closest to the mounting holes. Then insert D_r, D₁, etc., in that order. Secure the elements with the stainless steel 10-32 hex bolts and #10 lock washers provided. Complete the element installation by inserting the black end caps onto the ends of each element.

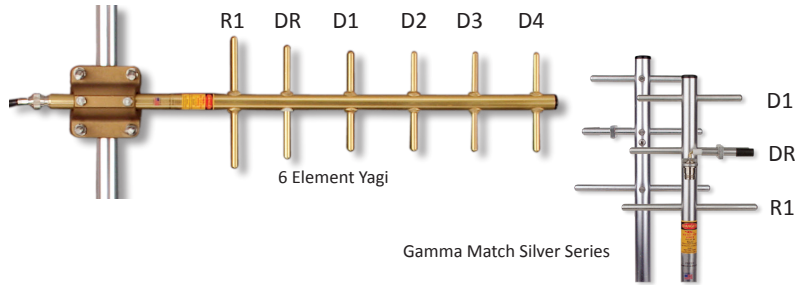

Y2503

Frequency (MHz)	Reflector (R1)	Driven (Dr)	Director1 (D1)
250	23-1/2	21-1/2	20
252	23-3/8	21-3/8	19-7/8
254	23-3/16	21-3/16	19-11/16
256	23	21	19-1/2
258	22-7/8	20-7/8	19-3/8
260	22-11/16	20-3/4	19-3/16
262	22-1/2	20-9/16	19-1/16
264	22-3/8	20-3/8	18-15/16
266	22-3/16	20-1/4	18-3/4
268	22	20-1/8	18-5/8
270	21-7/8	19-15/16	18-1/2
272	21-11/16	19-3/4	18-3/8
274	21-1/2	19-5/8	18-1/4
276	21-3/8	19-1/2	18-1/8
278	21-3/16	19-5/16	18
280	21	19-1/8	17-7/8
282	20-7/8	19	17-3/4
284	20-11/16	18-7/8	17-5/8
286	20-1/2	18-11/16	17-1/2

Y2505

Frequency (MHz)	Reflector (R1)	Driven (Dr)	Director1 (D1)	Director2 (D2)	Director3 (D3)
250	23-1/2	21-1/2	20	20	20
252	23-3/8	21-3/8	19-7/8	19-7/8	19-7/8
254	23-3/16	21-3/16	19-11/16	19-11/16	19-11/16
256	23	21	19-1/2	19-1/2	19-1/2
258	22-7/8	20-7/8	19-3/8	19-3/8	19-3/8
260	22-11/16	20-3/4	19-3/16	19-3/16	19-3/16
262	22-1/2	20-9/16	19-1/16	19-1/16	19-1/16
264	22-3/8	20-3/8	18-15/16	18-15/16	18-15/16
266	22-3/16	20-1/4	18-3/4	18-3/4	18-3/4
268	22	20-1/8	18-5/8	18-5/8	18-5/8
270	21-7/8	19-15/16	18-1/2	18-1/2	18-1/2
272	21-11/16	19-3/4	18-3/8	18-3/8	18-3/8
274	21-1/2	19-5/8	18-1/4	18-1/4	18-1/4
276	21-3/8	19-1/2	18-1/8	18-1/8	18-1/8
278	21-3/16	19-5/16	18	18	18
280	21	19-1/8	17-7/8	17-7/8	17-7/8
282	20-7/8	19	17-3/4	17-3/4	17-3/4
284	20-11/16	18-7/8	17-5/8	17-5/8	17-5/8
286	20-1/2	18-11/16	17-1/2	17-1/2	17-1/2

Y1363

Frequency (MHz)	Reflector (R1)	Driven (Dr)	Director1 (D1)
136	42-1/8	39	38
138	41-1/2	38-3/8	37-3/8
140	40-7/8	37-3/4	36-3/4
142	40-1/2	37-1/4	36-3/8
144	40-1/4	36-3/4	36
146	39-3/4	36-3/8	35-11/16
148	39-1/2	36-1/16	35-1/2
150	39-1/4	35-3/4	35-3/8

Y1365

Frequency (MHz)	Reflector (R1)	Driven (Dr)	Director1 (D1)	Director2 (D2)	Director3 (D3)
136	42-1/4	39	38	38	38
138	41-5/8	38-1/4	37-5/16	37-5/16	37-5/16
140	41-1/8	37-11/16	36-3/4	36-3/4	36-3/4
142	40-5/4	37-1/4	36-5/16	36-5/16	36-5/16
144	40-3/16	36-13/16	36	36	36
146	39-7/8	36-9/16	35-3/4	35-3/4	35-3/4
148	39-1/2	36-3/8	35-9/16	35-9/16	35-9/16
150	39-1/4	36-1/4	35-1/2	35-1/2	35-1/2

Y1503

Frequency (MHz)	Reflector (R1)	Driven (Dr)	Director1 (D1)
150	39-1/4	35-3/4	35-3/8
152	38-7/8	35-3/8	35
154	38-3/8	35	34-1/2
156	37-7/8	34-5/8	34-1/8
158	37-1/2	34-1/4	33-3/4
160	37	33-7/8	33-3/8
162	36-5/8	33-1/2	32-7/8
164	36-1/8	33	32-1/2
166	35-5/8	32-5/8	32-1/8
168	35-1/4	32-1/4	31-3/4
170	34-3/4	31-3/4	31-3/8
172	34-1/4	31-3/8	30-7/8
174	33-3/4	30-7/8	30-1/2

Y1505

Frequency (MHz)	Reflector (R1)	Driven (Dr)	Director1 (D1)	Director2 (D2)	Director3 (D3)
150	39-1/2	36-1/4	35-1/2	35-1/2	35-1/2
152	39	35-7/8	35-1/8	35-1/8	35-1/8
154	38-1/2	35-3/8	34-5/8	34-5/8	34-5/8
156	38	34-7/8	34-1/4	34-1/4	34-1/4
158	37-5/8	34-1/2	33-3/4	33-3/4	33-3/4
160	37-1/8	34	33-5/16	33-5/16	33-5/16
162	36-5/8	33-5/8	32-7/8	32-7/8	32-7/8
164	36-1/4	33-3/8	32-1/2	32-1/2	32-1/2
166	35-3/4	33	32-1/8	32-1/8	32-1/8
168	35-3/8	32-5/8	31-3/4	31-3/4	31-3/4
170	34-7/8	32-3/8	31-3/8	31-3/8	31-3/8
172	34-1/2	32-1/16	31	31	31
174	34-1/8	31-3/4	30-5/8	30-5/8	30-5/8

Y2203

Frequency (MHz)	Reflector (R1)	Driven (Dr)	Director1 (D1)
220	26	24-1/2	23-1/2
222	25-3/4	24-5/16	23-5/16
224	25-1/2	24-1/8	23-1/8
226	25-1/4	23-7/8	22-7/8
228	25	23-5/8	22-5/8
230	24-3/4	23-1/2	22-1/2
232	24-9/16	23-1/4	22-1/4
234	24-3/8	23	22
236	24-1/4	22-13/16	21-13/16
238	24-1/16	22-5/8	21-1/2
240	23-15/16	22-3/8	21-1/4
242	23-13/16	22-3/16	21
244	23-3/4	22	20-3/4
246	23-5/8	21-13/16	20-1/2
248	23-9/16	21-5/8	20-1/4
250	23-1/2	21-7/16	20

Y2205

Frequency (MHz)	Reflector (R1)	Driven (Dr)	Director1 (D1)	Director2 (D2)	Director3 (D3)
220	26	24-1/2	23-1/2	23-1/2	23-1/2
222	25-3/4	24-5/16	23-5/16	23-5/16	23-5/16
224	25-7/16	24-1/16	23-1/8	23-1/8	23-1/8
226	25-1/4	23-7/8	22-7/8	22-7/8	22-7/8
228	25	23-5/8	22-5/8	22-5/8	22-5/8
230	24-3/4	23-1/2	22-1/2	22-1/2	22-1/2
232	24-9/16	23-1/4	22-1/4	22-1/4	22-1/4
234	24-3/8	23	22	22	22
236	24-1/4	22-13/16	21-13/16	21-13/16	21-13/16
238	24-1/16	22-5/8	21-1/2	21-1/2	21-1/2
240	23-15/16	22-3/8	21-1/4	21-1/4	21-1/4
242	23-13/16	22-3/16	21	21	21
244	23-3/4	22	20-3/4	20-3/4	20-3/4
246	23-5/8	21-13/16	20-1/2	20-1/2	20-1/2
248	23-9/16	21-5/8	20-1/4	20-1/4	20-1/4
250	23-1/2	21-7/16	20	20	20

All charts shown in inches

Gamma Match Dimensions (Table 1)

Model	Freq.	Dim "A"	Dim "B"	Model	Freq.	Dim "A"	Dim "B"
Y1363	136	7-5/8"	4"	Y2203	220	6-3/4"	3-3/8"
Y1365	136	6-7/8"	3"	Y2205	220	4-3/8"	1-2"
Y1503	150	4-3/8"	2-3/8"	Y2503	250	7-5/8"	2-1/4"
Y1505	150	4-5/8"	3-5/8"	Y2505	250	7-1/4"	2"

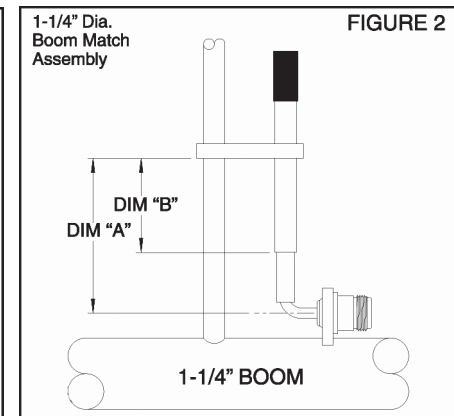
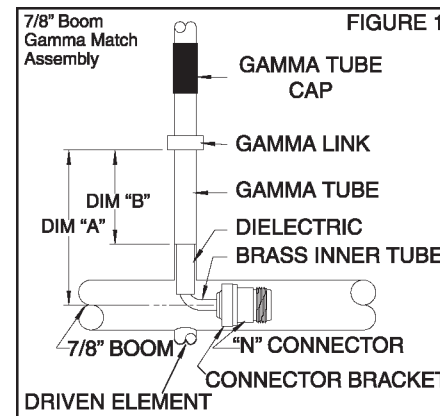

All charts shown in inches