

PUBLIC SAFETY/CRITICAL COMMUNICATIONS CATALOG



PULSTAR®





 **Microlab**

microlabtech.com

Public Safety / Critical Communications

Microlab has a 70 year history in Mission Critical Communications. We began in 1949 as a supplier of coaxial components for the Defense and Microwave industries. Since the 1990's Microlab has become a leader in the emerging commercial Distributed Antenna System (DAS) Market. Our components meet rigid electrical and environmental specifications and are in use world-wide by many of the largest System Integrators and Wireless Service Providers.

Our reputation and commitment to quality and performance is second to none. Microlab passive components cover all of the Public Safety/Transportation/Utility frequencies with products ranging from DC through 6 GHz and we were one of the first companies to understand and define the impact of PIM on these infrastructure systems. Microlab has built on that experience to introduce a new integrated solution specifically designed to monitor the network status of Public Safety communications systems. This solution features enhanced monitoring and reporting capabilities that are ideal for both new and existing networks.

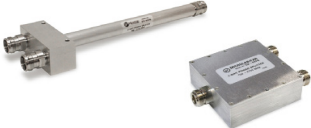
PUBLIC SAFETY PASSIVE COMPONENTS (Available with 7-16 DIN, N, 4.3-10 Connectors)		
Available Product Series	Features	Images
SMART Gateway <ul style="list-style-type: none"> • SCG100-AC • SCG100-DC 	<ul style="list-style-type: none"> • 138-960 MHz Headend unit • DAS Monitoring diagnostics and communications with up to 30 SMART Couplers via coaxial cabling • Monitors signal strength and VSWR for <i>Shorts, Opens, and properly terminated Antenna</i> 	
SMART Coupler <ul style="list-style-type: none"> • SC-xxN series 	<ul style="list-style-type: none"> • Broadband SMART Coupler 130-960 MHz • Replaces required passive DAS Tappers/directional couplers • Powered via 24VDC Bias over coaxial cable from the SMART Gateway • Monitors signal strength and VSWR for <i>Shorts, Opens, and properly terminated Antenna</i> • 6, 10, 15, 20dB Coupled port values 	
SMART Coupler <ul style="list-style-type: none"> • SC-xxN-450 series 	<ul style="list-style-type: none"> • Narrowband SMART Coupler 380-512 MHz • Replaces required passive DAS Tappers/directional couplers • Powered via 24VDC Bias over coaxial cable from the SMART Gateway • Monitors signal strength and VSWR for <i>Shorts, Opens, and properly terminated Antenna</i> • 6, 10, 15, 20dB Coupled port values 	
SMART Coupler <ul style="list-style-type: none"> • SC-xxN-850 series 	<ul style="list-style-type: none"> • Narrowband SMART Coupler 750-960 MHz • Replaces required passive DAS Tappers/directional couplers • Powered via 24VDC Bias over coaxial cable from the SMART Gateway • Monitors signal strength and VSWR for <i>Shorts, Opens, and properly terminated Antenna</i> • 6, 10, 15, 20dB Coupled port values 	
DC Pass Tappers <ul style="list-style-type: none"> • DN-x3FN 	<ul style="list-style-type: none"> • Enables DC Pass via coaxial cabling • Powers SMART Passives System and other critical communications monitoring that required DC continuity • 380-960 MHz • 50W Average • 2:1 through 100:1 RF power ratios 	
SPLITTER (REACTIVE/WILKINSON) <ul style="list-style-type: none"> • Dx-08 • Dx-41 • Dx-49 • Dx-67 	<ul style="list-style-type: none"> • 138 - 960 MHz or 380-2700MHz • 10 to 500W • 2, 3, and 4-Way • Very Low Insertion Loss • > 20 dB isolation (Wilkinson) 	

PUBLIC SAFETY PASSIVE COMPONENTS (Available with 7-16 DIN, N, 4.3-10 Connectors)

Available Product Series	Features	Images
TAPPER <ul style="list-style-type: none"> • DN-x1 • DN-x4 	<ul style="list-style-type: none"> • 137 to 960 MHz or 350 to 5925MHz • Splits: 2:1 to 1000:1 • 500 W average • Minimal RF insertion loss 	
DIRECTIONAL COUPLER <ul style="list-style-type: none"> • CK-7x1 	<ul style="list-style-type: none"> • 380 - 2700 MHz • Coupling: 3 to 50 dB • Directivity up to 25 dB • 100 to 200W • Low VSWR 	
HYBRID COMBINER/MATRICES <ul style="list-style-type: none"> • CA-93 • CM-99 	<ul style="list-style-type: none"> • 128 to 960 MHz • up to 100W • Ports: 2x2, 4x4 • up to 30 dB isolation • Low VSWR 	
DIPLEXER FILTER <ul style="list-style-type: none"> • BK-04 • BK-12 • BK-21 • BK-24 • BK-26 • BK-261 • BK-62 • BK-67 • BK-68 • BL-18PS • BL-26PS 	<ul style="list-style-type: none"> • 50 MHz to 2,700 MHz • Minimal Loss • Up to 50 dB isolation • 10 to 200W • Very low PIM 	
ATTENUATOR/TERMINATOR <ul style="list-style-type: none"> • TA series • TB series • TK-200 series • TK-25 • TK-27 • TK-28 • AM/N/P/Q/R • AS • AT • AU • AV-60F 	<ul style="list-style-type: none"> • DC to 3 GHz or 6GHz • 1W to 200W average • High Peak Power • Excellent VSWR • Low PIM Models Available 	
DC BLOCK <ul style="list-style-type: none"> • HR-20 • HR-22 • HR-25 • HR-28 	<ul style="list-style-type: none"> • 250 to 2,700 MHz • 250 to 500W • 3 kV High Voltage Rating • Minimal Loss 	
ANTENNA <ul style="list-style-type: none"> • YA-17NF 	<ul style="list-style-type: none"> • 380 MHz to 6.0 GHz • 60W • For Indoor Applications • Low PIM • Small Size and Light Weight 	
JUMPER CABLES <ul style="list-style-type: none"> • JA-10MN - N(m-m) • JA-10MX - 4.3-10(m-m) • JA-10MD - 7-16(m-m) • JA-10MY - 4.3-10(m)-7-16(m) • JA-10MA - 7-16(m)-N(m) • JA-10MZ - 4.3-10(m)-N(m) 	<ul style="list-style-type: none"> • DC to 6.0 GHz • 100W • 0.5 to 4 meters length • Multiple Connector Options • Low PIM 	

DCC RF Combiner / Point-of-Interface

DCC RF Combiners / POI have been designed to meet the needs for multiple service configurations for in-building systems, with low passive intermodulation (PIM). The example system shown combines up to 7 RF Inputs in the operating bands for 2 antenna feeds or distribution cables. Custom configurations are available up to 12 RF Inputs and can support frequencies from 136 MHz to 6 GHz.

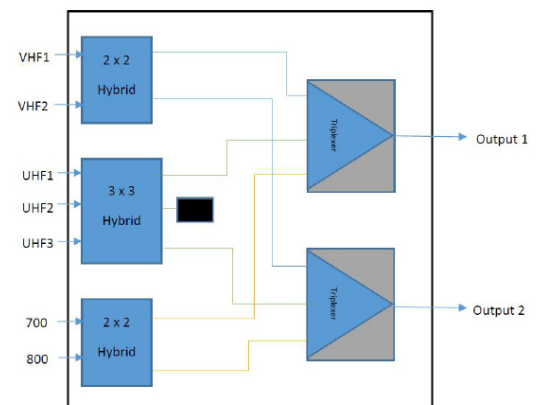

Microlab's patented System Monitoring Alarm Report Technology or SMART Passives System uses an embedded Internet of things (IoT) engine for monitoring an in-building, emergency responder radio communications system's (ERRCS) distributed antenna system's coaxial cabling and antennas.

The SMART Passives System consists of two main components: SMART Gateway at the ERRCS head-end and up to 30 SMART Couplers throughout a building's risers and coverage cabling and antennas. SMART Couplers are a direct replacement for the required tappers or directional couplers for equalizing RF energy floor over floor. SMART Gateway and SMART Couplers are DC powered and communicate all diagnostic information between the SMART Gateway and SMART Couplers over the coaxial cabling. Local power and LAN connectivity are not required at each SMART Coupler.

SMART Passives continuously monitor RF signal power and VSWR watching for DAS integrity degradation including short or open circuit conditions, or a properly terminated antenna for optimum public safety radio transmissions.

SMART Couplers are available broadband 130-960 MHz and narrowband 380-512 MHz or 750-960 MHz with coupled port values are 6, 10, 15, and 20 dB.

SMART Passives System meets the requirements set by many authorities having jurisdiction.



SMART Gateway



**SMART Coupler,
Broadband, 130-960 MHz**



**SMART Coupler,
Narrowband, 380-512 MHz**



**SMART Coupler,
Narrowband, 750-960 MHz**

Learn more at: microlabtech.com

For more information about Microlab contact your local representative.

Find a complete list here: microlabtech.com/sales/

Microlab

25 Eastmans Road
Parsippany, NJ 07054, USA
P: +1 (862) 328-1101
sales@microlabtech.com